

Technical Data Sheet: CULTEX® RFS Compact Radial Flow System for Cell-based Exposure



The Airborne Exposure Experts



The CULTEX® RFS Compact is designed to house one type of cell culture insert size. The new modular system consists of two main parts, the aerosol-guiding module and the sampling module housing six cell culture inserts, which are separately supplied with medium. The module can be used for analyzing the biological effects of the test atmosphere in all insert positions. Another option allows exposure of the cell cultures to the test atmosphere and clean air (negative control) in parallel by guiding the aerosol via the central inlet to three insert positions, whereas the three remaining insert positions are connected to clean air.

Exposure systems

General features

- Direct exposure technology at the air-liquid interface of cell cultures
- Cellular systems: cell lines and primary cells from the respiratory tract as mono- or co-cultures
- Test compounds
 - Gases
 - Particles (fine to nanoparticles)
 - Complex mixtures (e.g. tobacco smoke)
- Application areas
 - Industrial chemicals (particulate & gaseous compounds)
 - Consumer products
 - Tobacco smoke
 - E-cigarette vapor
- Pharmaceutical and therapeutic products
- Pesticides
- In- and outdoor analysis
- Clients
 - Universities
 - Regulatory bodies
 - Military
 - Pharmaceutical, chemical and tobacco industry
 - Contract research laboratories

Basic principles of the exposure systems

Module design

- Inlet adapter
- Exposure top – Aerosol guiding module
- Base module – Sampling module
- Socket module
- Rack module

Dilution

- Use of the system with or without dilution

Test atmosphere

- One sampling point
- Radial flow system
- Homogeneous distribution of the test atmosphere to the surface of the cells
- Reproducible deposition of the particles on the cell surface
- Establishment of dose-response relationships
- Repeated exposure studies

Biological test system

Cells

- Maintenance of cell viability
 - 37° C by electronic heating
 - Static medium supply from below the insert membrane
- Application of 6.5 mm and 12 mm Falcon® or Transwell® inserts via special adapters

Technical Data Sheet:

CULTEX® RFS Compact – Radial Flow System for Cell-based Exposure

Air-liquid interface – *in vitro* exposure

Exposure systems – CULTEX® RFS Compact

- Flexible design of the exposure top for conducting parallel exposure of the cells to clean air and the test aerosol or to one type of atmosphere
- Only for 6.5 or 12 mm Falcon®/Transwell® inserts
- 6 exposure positions

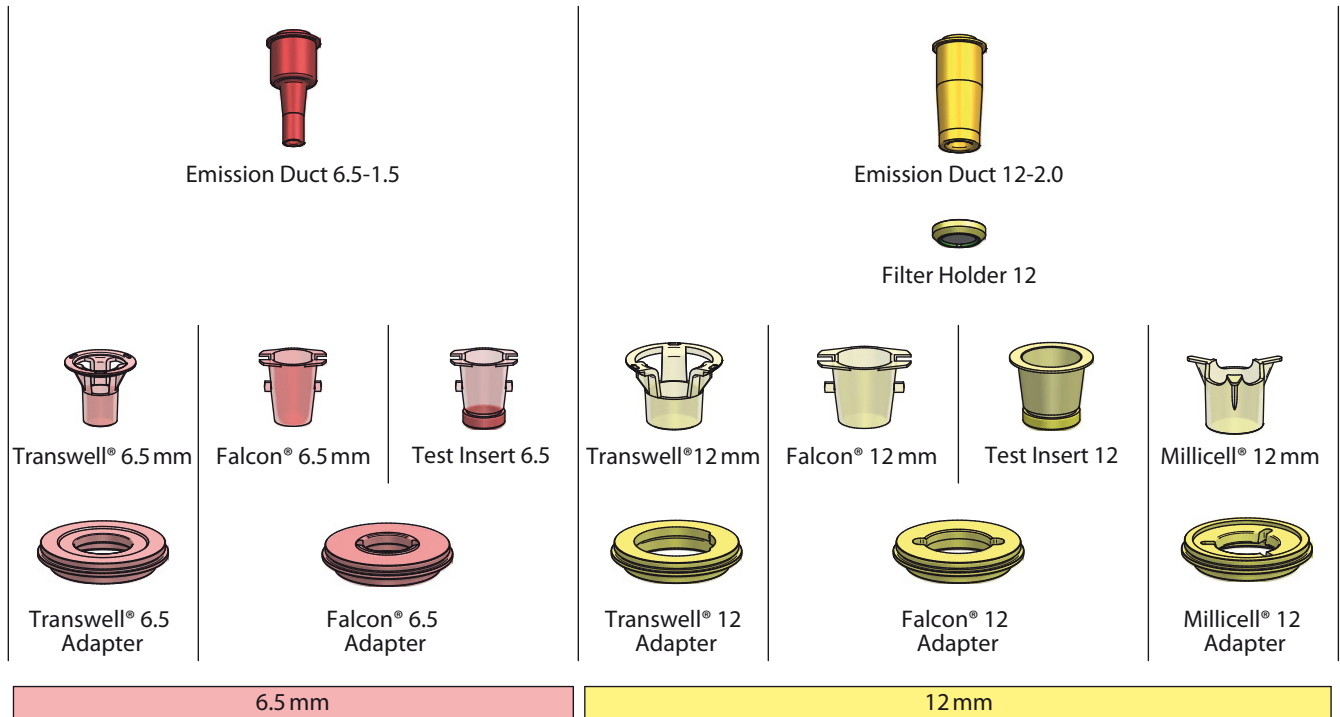

Atmosphere **and** clean air

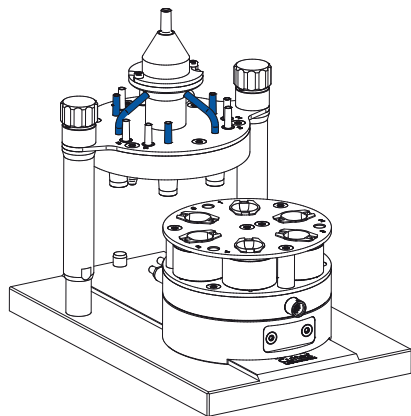

Atmosphere **or** clean air

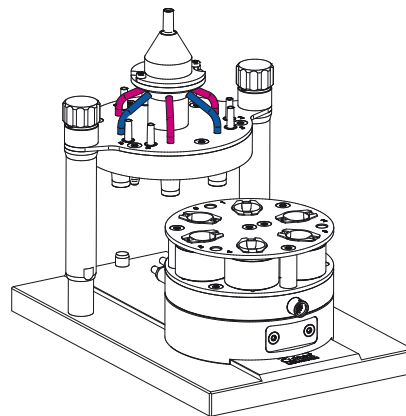

The Airborne Exposure Experts

Contact us:
Cultex® Technology GmbH · Feodor-Lynen-Straße 35 · 30625 Hannover · Germany · Phone: +49 (0)511 80687579 · www.cultex-technology.com · info@cultex-technology.com
 Our products are subject to continuous development and we reserve the right to amend specifications without notice.
 © 2018 Cultex® Technology GmbH. All rights reserved. Version 2.0 | Design by ahlersheinel.com